

*PROII™ Drawer Unit Tool Cabinets

ModuLine Aluminum Drawer Unit Tool Cabinet Features

- Completely assembled, ready to install.
- Drawer Unit Tool Cabinets will stand alone and stay tight and strong even under the most extreme conditions.
- Easy one-handed operation.
- Full extension smooth ball bearing drawer slides
- Stand alone as needed or use with base cabinets.
- Available in red, white and black.
- Custom designs and colors are also available.
- Top with aluminum stainless steel or butcher block counter tops.
- Lightweight Aluminum Drawer Cabinets.

*Pat. Pending



Drawer Unit #402432DUTK Shown

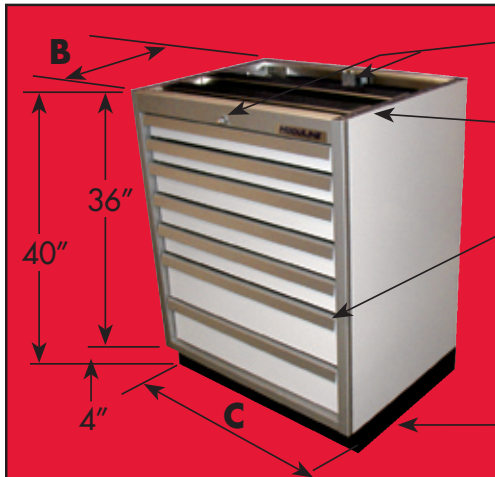

Thumb lock and positive drawer latch mechanism keeps all drawers closed and allows locking with one key.

Extra rigid integrated frames are high quality aluminum with double reinforced corners.

Handles and front frames are clear anodized premium aluminum for good looks and durability.

4" Toe Kick Riser™

- Recessed 2" from front of cabinet for easy floor cleaning and comfortable foot space when standing in front of cabinets.
- Allows for adjustment between riser and base to compensate for uneven floors.



Drawer Unit #632432DUTK Shown

Tool Cabinets					
Part No.	Lbs.	Height	Depth	Width	Drawers
361832DU	95	36	18	32	7
362432DU	127	36	24	32	7
401832DUTK	100	40	18	32	7
402432DUTK	134	40	24	32	7
592432DU	213	59	24	32	12
632432DUTK	220	63	24	32	12



Aluminum Drawer Dividers

3" and 6½" deep.
Additional Separators available,
see page 20 for details.

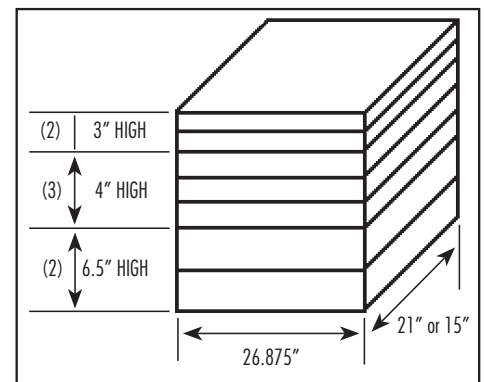
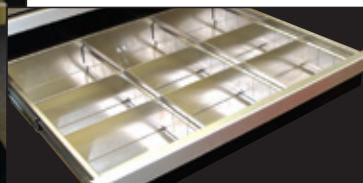

Drawer size diagram for 36" tall Tool Cabinet

*PROII™